



LNG
insulation

Insulated pipe
Supports

Site Production
of Blocks

Chemicals for
in situ application

DUNA products for industrial insulation
Cold and Cryogenic



DUNA products for industrial insulation

Cold and Cryogenic

Why PIR and PUR?

- Low thermal conductivity**
 The thermal conductivity rating of CORAFOAM® rigid polyurethane/polyisocyanurate foams (PIR/PUR) is the lowest value among expanded materials for insulation.
 - Strength**
 CORAFOAM® polyurethanes and polyisocyanurates provide the best balance of physical-mechanical properties and density.
 - Lightness**
 The foam structure consists of fine closed cells containing blend of gases which grant excellent insulation properties, and extreme lightness.
 - Low water absorption and low vapour permeability**
 Keeping water off any insulation is crucial. Thanks to its particular chemical structure, CORAFOAM® shows very low values of water absorption and permeability.
 - Dimensional Stability**
 Thanks to its specific composition and polymer structure rigid PIR/PUR foams show significant performances in size stability in a wide range of operating temperatures with an expected service life of 30+ years.
 - Chemical resistance & Compatibility**
 The chemical composition of rigid polyurethane foam provides excellent resistance to a wide range of chemicals, solvents and oils and makes it compatible with a large number of auxiliary materials such as adhesives, mastics etc.
 - Range of service temperatures**
 Rigid PIR/PUR foams are suitable for applications in a wide range of temperatures from extreme cryogenics (-200°C /-328°F) up to hot water (+120°C/+248°F); some materials can even withstand +205°C (+400°F).
 - Fire properties**
 Polyurethanes can be formulated to meet the highest classes of the most stringent fire protection standards. Our P series of PIR foams meet the requirements of ASTM E 84 Class A (FSI < 25 and SDI <450).
- For these reasons PIR/PUR foams are extensively used in industrial insulation applications, especially when energy savings is a key factor in the performance of the plant.
- Liquefied Natural Gas (LNG)**
 The natural gas is liquefied at approximately -162 °C (-260 °F); PIR and PUR have a key role in all aspects of the supply chain, from liquefaction, through insulation of the tanks on LNG carriers until the regasification terminal.

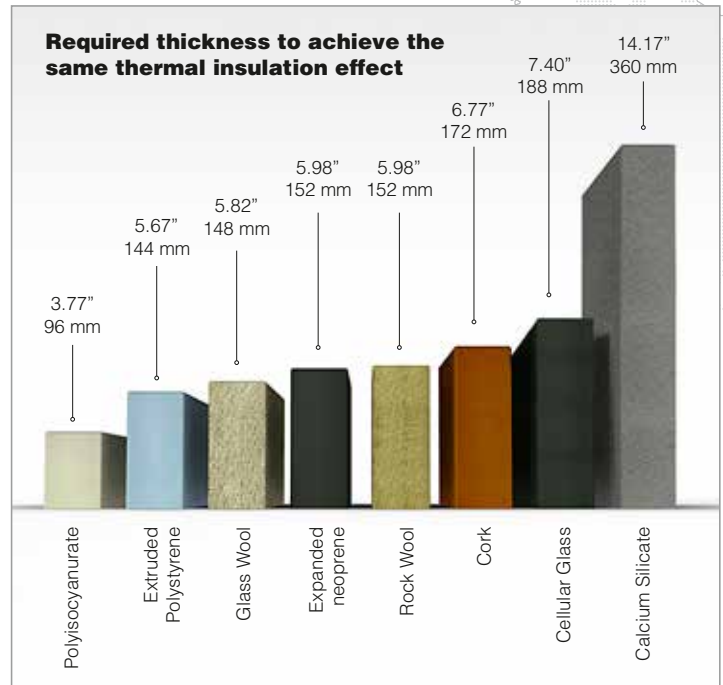

Thermal conductivity values of other materials come from the databases and technical data sheets of various manufacturers.

- Ethylene**
 Ethylene is the first building block for most plastics and it is produced through synthesis of natural gas and stored at a temperature of -104°C (-155°F)
- LPG**
 LPG is refined and condensated from petroleum and 'wet' natural gas. Its storage temperatures are between -10 and -45°C (14°F/-49°F), therefore it is considered "soft cryogenic".
- Ammonia/Fertilizer**
 Ammonia contributes significantly to the nutritional needs being a fertilizer, being at the same time a building block for the pharmaceutical industry. Ammonia is synthesized starting from natural gas and it's stored at around -40°C (-40°F).
- Underground Oil ducts**
 The oil is kept fluid at about 80°C (176°F); in this case PIR/PUR serve as hot insulation. Thanks to their great resistance to organic decay, these foams are strongly used for long durability and low maintenance oil pipelines.

Our products for cryogenic insulation

1. PIPE INSULATION

CORAFOAM®



PUR/PIR Blocks

**CORAFOAM®
DUNAPIE**



Fabricated Pipe Sections

**CORAFOAM®
DUNAPIE**



Fittings (valves, flanges, elbows, reducers)

DUNAPOL® C



In-situ foam and injection systems

**DUNAPOL®
SPINPIPE**

pouring and spray



Pre-insulation

2. PIPE SUPPORTS, THERMAL BREAKS AND COLUMN BEARINGS

**CORAFOAM®
BLUE CORINTHO® HT**

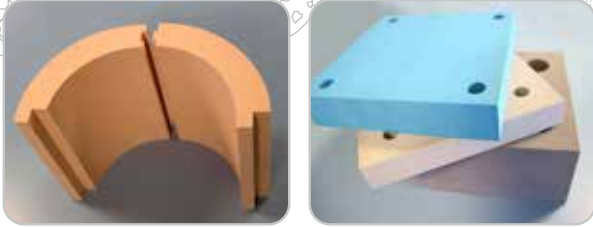

PIR/PUR Fabricated pieces

3. PRODUCTS FOR ASSEMBLING

DUNAPOL® C



Injection system

**DUNAPOL® AD
DUNAPOX AD**



PU/Epoxy Adhesives

4. LAND STORAGE TANKS/MARINE TANKERS

DUNAPOL® S



PU Spray System

CORAFOAM®



PIR/PUR Panels

CORAFOAM®

The ideal solution for great numbers of applications, CORAFOAM® PIR/PUR is supplied in blocks, or shaped into fabricated pieces on customer's design (DUNAPIPE). Pipes, flanges, valves, elbows, tees, reducers can be single or multilayered, but jointed, shiplapped, with or without factory applied DUNAPAP film.



BLUE CORINTHO® HT

High density rigid PIR material (700-800 kg/m³, 43.7-50 lb/ft³), suitable for supports, thermal breaks and column bearings.



DUNAPOL® C

PIR/PUR systems for in situ foam and injection, with tailor made formulations able to match customers' and project requirements.



DUNAPOL® S

Formulated spray system for both onshore and offshore, approved by classification societies for onboard insulation on vessels carrying liquefied gases.



DUNAPOL® SPINPIPE

DUNAPOL® SPINPIPE, PIR system for pre-insulation by pouring on rotating pipe. Seamless and in line with the strictest cryogenic specifications, SPINPIPE improves both scheduling and quality control, reducing labor. The system is available also for SPRAY application.



DUNAPOL® / DUNAPOX AD

Line of structural polyurethane or epoxy adhesives able to bear cryogenic temperatures available in 1,2 or 3 components, packed in small handy ready-to-use solutions. Reaction speed and viscosities are tailor-made to suit specific customer's requests. DUNAPOL® and DUNAPOX AD are suitable to glue PUR, PIR, metals, wood, cellular glass etc.



MOST REQUESTED CORAFOAM® FOR INDUSTRIAL INSULATION:

Product	Density	Blowing Agent	Compressive Resistance - Parallel (74°F)	Thermal Conductivity 180 days (74°F)	Closed cell content	Fire properties	Operating Temperature
Standard	ASTM D 1622		ASTM D 1621	ASTM C 518	ASTM D 6226	ASTM E 84	ASTM C 591
U.M.	lb/ft ³		psi	BTU-in/hr.°F-ft ²	%		°F
P20	2	HFCs/CFCs/HCFCs-free ODP=0 and GWP<10	32	0.183	>95	Class A FSI < 25 and SDI < 450	-328/+300
P25 / PB40M1-HC	2.5	HFCs/CFCs/HCFCs-free ODP=0 and GWP<10	46	0.183	>95	Class A FSI < 25 and SDI < 450	-328/+300
P30 / PB50M1-HC	3	HFCs/CFCs/HCFCs-free ODP=0 and GWP<10	58	0.185	>95	Class A FSI < 25 and SDI < 450	-328/+300
HPT 35	2.2	HFCs/CFCs/HCFCs-free ODP=0 and GWP<10	39	0.183	>95	-	-58/+212
HPT 40	2.5	HFCs/CFCs/HCFCs-free ODP=0 and GWP<10	50	0.183	>95	-	-58/+212
HPT 50	3.1	HFCs/CFCs/HCFCs-free ODP=0 and GWP<10	69	0.185	>95	-	-58/+212
U40	4	CO2	83	0.24	>95	-	-328/+176
U60	6	CO2	148	0.25	>95	-	-328/+176
U80	8	CO2	230	0.26	>95	-	-328/+176
U100	10	CO2	290	0.28	>95	-	-328/+176
U150	15	CO2	590	0.32	>95	-	-328/+176
U200	20	CO2	1131	0.39	>95	-	-328/+176
U280	28	CO2	2233	0.51	>95	-	-328/+176
U310	31	CO2	2436	0.52	>95	-	-328/+176
BLUE CORINTHO HT 700	43	CO2	4061	0.75	-	-	-328/+400



CORAFOAM®

Installation Guidelines

AIM

This installation guide is intended to suggest materials and installation practices for products manufactured by DUNA-Group in the following applications:

- Tank Insulation
- Piping Insulation
- Mechanical Insulation
- Duct Insulation

Properly set up insulation and its maintenance is of extreme importance, so that the insulated system works with the efficiency for which it was designed at the beginning. It is crucial to identify which is the aim of the insulation requested by the system. We indicate here below some of the main purposes:

- Condensation control
- Energy efficiency
- Freeze protection
- Personnel protection
- Process control

Typically, insulation works for an industrial plant project are supported by a dedicated technical specification, issued by qualified Engineering companies, to match project demands. Such document considers local conditions, work out, environment and desired function life, so it prevails on any other technical document, including this guideline.

GENERAL INFORMATION

All insulation material shall be delivered to the project site in original, unbroken factory package distinguished with product designation and thickness. The shipping package should not hold moisture in the event of accidental wet weather. Materials on the job-site shall be warehoused so as to protect the materials from moisture and weather during storage and installation. Insulation material shall be protected from sunlight to prevent UV exposure.

SURFACE CLEANING

Before starting installation, all welding work must be terminated and dust, oil, grease, loose particles, frost and moisture must be removed from surfaces. It is better to have all critical parts primer-painted in order to avoid corrosion.

FABRICATION OF INSULATION

Project specification

All parts must be manufactured starting from cured blocks by in accordance with ASTM C 585. For best fabrication outcomes, it is advisable the foam blocks be cut into pipe shells in length direction to maximize flatness.

Sealers, glues and mastics

Glues, joint sealers and mastics, including the solvent based ones, may be used in contact with all DUNA insulation products. Compounds that remain flexible at the working temperature of PIR foam per table on page 8 are the ones authorized by the DUNA Group. A vapour retarder type joint sealer shall be used on insulation longitudinal joints and butt joints to avoid moisture infiltration. Ask joint sealer original manufacturers for suitable products. Solvent or water based glues may be employed to fix the vapour barrier to the outer surface of Insulation. Refer to vapour barrier installation guidelines and consult specialized manufacturers for a list of products and installation guidelines.

Ask our sales office for our DUNAPOL®/DUNAPOX adhesives.

Vapour barriers

Vapour barriers are requested on all cellular structured insulation materials. They are normally distinguished into 2 main families:

- Secondary Vapour Barriers (SVB), also known as Vapour Retarder
- Primary Vapour Barrier (PVB) A double layer vapour barrier is strongly suggested for LNG applications.

The SVB shall be applied directly over the innermost layer of a 2 layer system and the middle layer of a 3 layer system while the PVB will be applied on the outermost layer. SVB is backing up possible failures of the PVB allowing repairing activities without compromising the system safety. The typical SVB is consisting of Polyester-Aluminium-Polyester film (PAP). References are made to ASTM standards C 755 and C 1136 for information on choice and specification of vapour barriers. Refer to product literature and installation guidelines from the PVB and SVB manufacturer for recommended application instructions. The drawings included at the end of this guide are representative of details commonly used within the field, however, they are not meant to show the only recognized method of installation but to work as an example of commonly used and standard practices. PVBs are normally applied in-situ after the installation of the insulation, directly over the outermost layer of insulation and can be of different nature, e.g. Bitumen mastics, Butyl Rubbers, etc. It's strongly recommended to strictly follow project specification for the selection of the approved PVB and their application.

Contraction/Expansion joints

Contraction/expansion joints must be foreseen in order to mediate the movements of insulation parts following the thermal contraction-relaxation due to thermal gaps. Their position should be regulated considering the expected pipe movements. They should be installed in the inner insulation layers of the horizontal piping and equipments. Typically the joints are placed at maximum intervals of 6 mt (20 feet). The project engineer is to determine the appropriate position of the contraction/expansion joints for each system. Contraction/expansion joints should be filled with resilient mineral fibers or approved alternatives, with fibers oriented parallel to the direction of the pipe. The filler, in relax status, should be twice the length of the contraction/expansion joint to be packed to the joint length during installation. The project engineer is to determine the appropriate contraction/expansion filler material.

Jacketing materials

Jacketing materials are mainly intended to mechanically protect the insulation and shall not be considered as vapour barrier. Typical materials for jacketing purposes are aluminum and stainless steel.

Aluminum Cladding

Covering shall be aluminum alloy meeting ASTM B209-10. Consult the project specification and jacketing manufacturer for suggested thicknesses. Aluminum jacketing for all fittings, tees, elbows, valves, caps, etc. shall be sectional, or field fabricated to conform tight around the insulation. Banding for jacketing shall be 0,5 mm (0.02") thick by 12,7 mm (1/2") wide stainless steel. No fastener able to penetrate the primary vapour barrier shall be used to fix the aluminum jacket.

Stainless Steel Cladding

The material shall be selected meeting the requirements of ASTM A 167. Consult the project specification and jacketing manufacturer for suggested thicknesses. Stainless steel jacketing for all fittings, tees, elbows, valves, caps, etc. shall be sectional, or field-fabricated to conform tight around the insulation. Banding for jacketing shall be 0,5 mm (0.02") thick by 12,7 mm (1/2") wide stainless steel. No fastener able to penetrate the primary vapour barrier shall be used to fix the stainless steel jacket.

Insulation Thickness	Layering	Joints type
Until 50 mm (2")	Single Layer	Shiplap
Between 50 mm (2") and 127 mm (5")	Double layer	Butt joints
Above 127 mm (5")	Triple layer	Butt joints

1- LAYER SYSTEM

When a single layer is requested, it is suggested to fabricate insulation parts with shiplap or tongue and groove longitudinal joints and shiplap ends. Insulation in a single layer system shall be fixed to the pipe with 19 mm (3/4") wide fiber strengthened tape.

2- LAYERS SYSTEM

For double layers, all longitudinal joints between the inner and outer layers must be staggered by shifting and rotating parts of the various layers in order to avoid alignment of joints between interior and exterior parts; this helps to minimize the risk of thermal bridge. The best solution is to stagger the parts while installing as indicated in the pictures at the end of this guideline. In a 2-layers insulation system, the internal layer shall not be fixed with sealants. The internal and external layer shall remain autonomous of each other in order to allow movement between the layers.

3- LAYERS SYSTEM

Where insulation thickness is larger than 127 mm (5") and a triple layer system is requested, stagger all longitudinal joints between the inner, middle, and outer layers. The best solution is to stagger the parts while installing as indicated in the pictures at the end of this guideline. In a 3-layer insulation system, the inner layer shall not be fixed with sealants. The inner, middle and outer layer shall remain autonomous of each other in order to allow movement between the layers.

FITTINGS

Pre-fabricated insulation for fittings like elbows, tees, and valves shall be the same thickness as pipe sections and fabricated with shiplap ends or tongue and groove longitudinal joints to connect to the pipe insulation system.

INSTALLATION AND SECONDARY VAPOUR BARRIER DUNAPAP

Insulation shall be attached with fiber strengthened tape on both internal and external layers of a multi-layered systems. External layer insulation and secondary vapour barrier (SVB) shall be fixed with fiber strengthened tape. Use a 25% overlap when secondary vapour barrier is factory applied to insulation. Fiber tape shall be positioned to the exterior of the insulation/secondary vapour barrier system. Secondary Vapour Barrier Film should be cut to length longitudinally and covered around the circumference of the pipe with lap joint and placed facing downward abstaining from the placement of the joint at the top or bottom of the pipe. Lap joints are to be sealed using a liquid glue. Butt joints shall be protected with vapour barrier tape. Coiling wrap configuration can be employed instead of the above installation. Coiling wrapping will necessitate adhesive placed on one edge of the vapour barrier as it is wrapped over the preceding layer. On factory applied secondary vapour barrier film, lap joint to be sealed with Self Seal Lap Tape (SSL). All secondary vapour barrier surfaces should be free of dust, grease, oil and other materials and duly cleaned. Before positioning the SSL tape make sure that there is a good adhesion between the tape and vapour barrier. For other kinds of factory applied secondary vapour barriers, ask manufacturer's instructions on positioning.

PRIMARY VAPOUR BARRIER AND VAPOUR STOPS

Vapour stops shall be used on either side of valves often removed for inspections, valve place left uncovered, or uneven fittings, elbows, tees, etc. where the possibility of moisture infiltration is high. All insulation shall be tightly fixed and free of voids, spaces and gaps at all joints. Vapour barrier must be continual. Before jacketing can be positioned on a portion of the piping, the vapour barrier system on that portion must be terminated and continual.

OUTDOOR PIPING

Specific attention must be paid for insulation applied in outdoor areas to avoid natural agents compromising the insulation works. Insulation shall be defended from protracted exposure to UV rays and weather upon installation. It's necessary to provide jacketing material within two weeks from positioning in order to avoid Ultra Violet degradation. Outdoor jacketing overlap shall be a minimum of 50 mm (2") at butt joints and a minimum of 50 mm (2") at longitudinal joints. Jacketing shall be weather stripped before closing and banding and positioned in order to avoid water infiltration. Straight sections of jacketing shall be with bands and seals with a maximum spacing of 229 mm (9") on center. End joints shall be fixed with bands and seals centered directly over joint. Do not use screws, staples or other fasteners that could affect the vapour barrier system.

TANK, VESSEL AND EQUIPMENT INSULATION

All insulation materials shall be the same as those used on the pipe interacting with the tank, vessel, or equipment. Tank and vessel head segments shall be to conform in single piece or segments to ASTM C 450. Head segments shall be cut so as to eliminate voids at the head section and with the minimum possible number of pieces. Curved segments shall be fabricated to fit the outline of the surface in equal size pieces to fit around the vessel with a minimum number of joints. Cutting in the field shall be minimized as much as possible. All sections shall be tightly clenched and free of voids, space and gaps. Vertical vessels greater than 4 feet in diameter may need an insulation back up ring welded or bolted around the bottom of the tank to preclude the shell insulation from slipping down. Seal all outer layers and single layer butt joints with joint sealer. In multi-layer applications, the horizontal and vertical joints of the internal and external layer segments shall be staggered. Fix the shell insulation with stainless steel bands. Place the seams by a minimum of 2 inches. Seal the overlapped seams with vapour barrier tape. On vertical vessels apply the SVB film beginning with the bottom course and work upwardly. Each layer should overlap on top of the lower one resulting in a joint that will naturally shed water. The vapour barrier on curved head sections shall be mastic/ fab/mastic or authorized other. Flat head sections can be wrapped with vapour barrier film.

CORROSION RESISTANT METAL COATINGS

Corrosion of metal pipe, vessels, and equipment under insulation, while not usually determined by the insulation, is still an important issue that must be taken into consideration in any mechanical insulation system. The predisposition for corrosion depends on many causes including the ambient environment and the operating temperature of the metal. DUNA foams are friendly to every type of primer solution, nevertheless we suggest corrosion engineers to work closely with the fabricator, the contractor, and DUNA's technician to help guarantee a properly designed, made, and long-lasting corrosion-free insulation system.

FULL THICKNESS SHIPLAP ELBOW FITTING

- Shiplap end cut to thickness "X" to accommodate double layer pipe insulation.
- Can be used instead of double layered fittings if project specification allows.
- Cover elbow with vapour barrier tape.

TAPING PATTERN

- Use two wraps of tape to guarantee proper bond.
- Use nylon or glass filament type tape 19 mm (3/4") wide.

DOUBLE LAYER EXPANSION / CONTRACTION JOINT DETAIL

Allow sealant beads to cure prior to positioning of external layer.

- Position external layer packed glass fiber between sealant dams on internal layer.
- After glass fiber in contraction joint is laid down, insulation sections on either side of contraction joint shall be pushed together as tightly as possible.

VAPOUR STOP DETAILS

- Mastic should be determined on the service temperature of the system.
- Mastic shall be sealed to the pipe face and lapped back over the top of the vapour barrier if fitting is left exposed

VAPOUR BARRIERS DETAIL

- Vapour Barrier can be installed using SSL tape or using liquid glues.
- Butt joints to be wrapped a minimum of 44 mm (1.5") on each side of joint by vapour barrier tape or butt strip.

TANK HEAD INSULATION DETAIL

- In multiple layer systems, each layer shall be positioned so that the horizontal and vertical joints in that layer are offset from the matching joints in the previous layer by half the height or width of a full section.

- At joint between wall and head section, the external layer shall be offset below the internal layer by the thickness of a single layer.
- Where mastics or sealants are needed to fix the insulation sections to the tank head ask the manufacturer's recommendations on service and application temperatures.

INSULATION THICKNESS

The customer's engineer should be asked to guarantee the insulation thickness necessary to avoid condensation on the external surface of the insulation system jacketing. In a few cases, the thickness must also guarantee the insulation thickness necessary to limit the heat gain to a specific value (usually 25 Watt/m² (8 btu/hr-ft²) of external jacketing surface). A number of assumptions must be made, based on indoor/outdoor, humidity, wind, cycling, safety factors, and so on. We suggest you asking a qualified engineer and have them work closely with the contractor, and DUNA to help guarantee a properly designed, positioned, and long-lasting insulation system.

Economic thickness, therefore, is defined as the thickness of insulating materials that minimizes the total-cost curve, this curve being the sum of the cost of installed insulation and the cost of energy loss.

At low thickness values, the cost of insulation is low, but the cost of energy loss is high. Additional thickness reduces the loss of energy, but only up to a certain point, beyond which adding further insulation is not useful anymore.

The use of certified mechanical insulation inspectors who maintain current certification by the National Insulation Association, or other certified mechanical insulation certification association, is recommended throughout the project to inspect and verify the materials are and the total insulation system has been installed in accordance with the specifications.

The data reported in the tables included in this guideline are for reference only, we suggest to use the 3E plus program available at <https://insulationinstitute.org/tools-resources/free-3e-plus/> keeping in mind that project specifications may prevail.

Economic Balance of Insulation

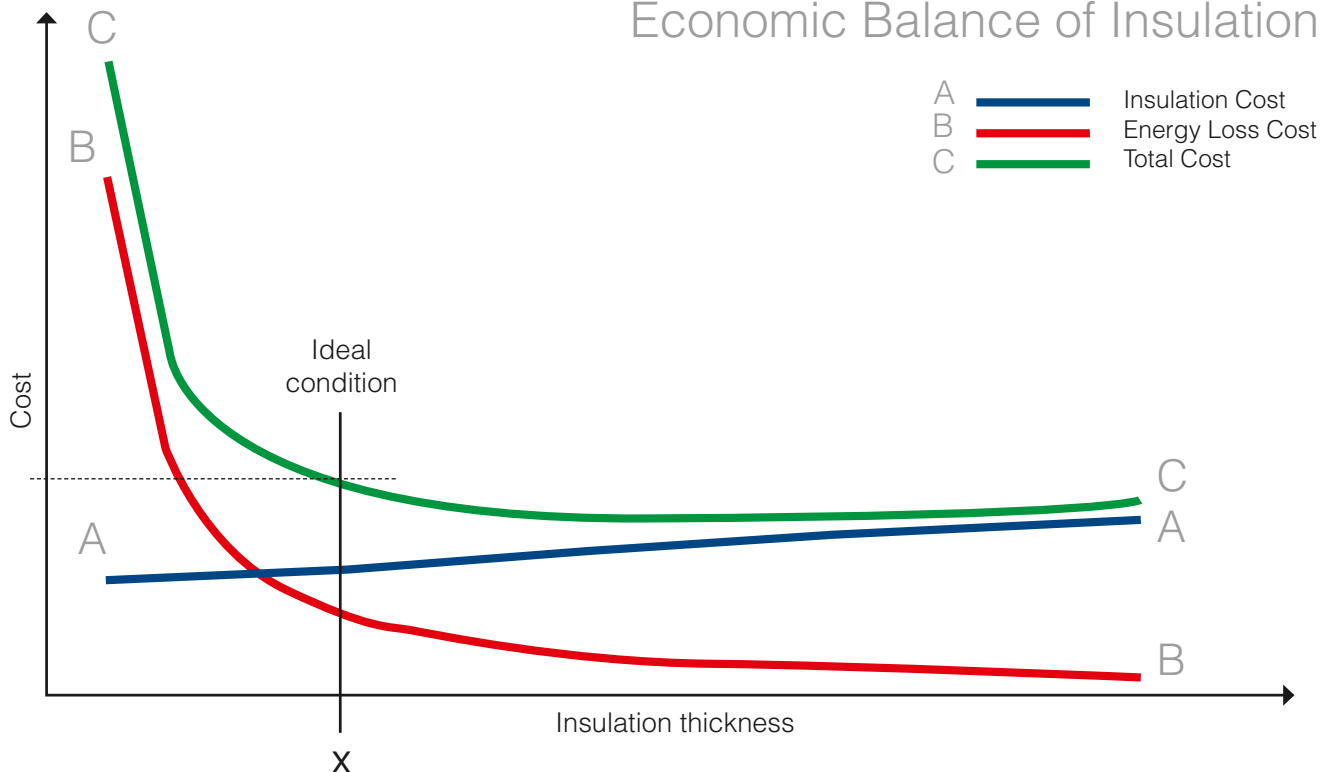

COLD SERVICE INSULATION

HR	80%
Average Ambient T	95°F
Wind Speed	2,2 km/h (1.4 miles/hour)
Max Heat Gain	8 BTU/h-ft ²
Jacket Emissivity	0,9
Dew Point	88°F



PIPE DIAM ^W	Service Temperature °F									
	0	-4	-40	-76	-112	-148	-184	-220	-265	-292
1/2"	1.5"	1.5"	2.0"	2.0"	2.0"	2.5"	2.5"	3.0"	3.0"	3.5"
1"	1.5"	1.5"	2.0"	2.0"	2.5"	2.5"	3.0"	3.5"	3.5"	4.0"
1 1/2"	1.5"	2.0"	2.0"	2.0"	2.5"	3.0"	3.5"	3.5"	4.0"	4.0"
2"	1.5"	2.0"	2.0"	2.5"	3.0"	3.0"	3.5"	4.0"	4.0"	4.0"
2 1/2"	1.5"	2.0"	2.0"	2.5"	3.0"	3.5"	3.5"	4.0"	4.0"	4.0"
3"	1.5"	2.0"	2.0"	2.5"	3.0"	3.5"	4.0"	4.0"	4.0"	4.5"
4"	1.5"	2.0"	2.0"	2.5"	3.0"	3.5"	4.0"	4.0"	4.5"	4.5"
6"	1.5"	2.0"	2.5"	3.0"	3.5"	4.0"	4.0"	4.5"	4.5"	5.0"
8"	1.5"	2.0"	2.5"	3.0"	3.5"	4.0"	4.0"	4.5"	5.0"	5.5"
10"	1.5"	2.0"	2.5"	3.0"	3.5"	4.0"	4.5"	4.5"	5.0"	5.5"
12"	1.5"	2.0"	2.5"	3.0"	4.0"	4.0"	4.5"	5.0"	5.5"	6.0"
14"	1.5"	2.0"	2.5"	3.0"	4.0"	4.0"	4.5"	5.0"	5.5"	6.0"
16"	1.5"	2.0"	2.5"	3.5"	4.0"	4.0"	4.5"	5.0"	5.5"	6.0"
18"	1.5"	2.0"	2.5"	3.5"	4.0"	4.0"	4.5"	5.0"	5.5"	6.0"
20"	1.5"	2.0"	2.5"	3.5"	4.0"	4.0"	4.5"	5.5"	6.0"	6.0"
22"	1.5"	2.0"	2.5"	3.5"	4.0"	4.0"	5.0"	5.5"	6.0"	6.0"
24"	1.5"	2.0"	2.5"	3.5"	4.0"	4.5"	5.0"	5.5"	6.0"	6.0"
26"	1.5"	2.0"	2.5"	3.5"	4.0"	4.5"	5.0"	5.5"	6.0"	6.0"
28"	1.5"	2.0"	2.5"	3.5"	4.0"	4.5"	5.0"	5.5"	6.0"	6.0"
30"	1.5"	2.0"	2.5"	3.5"	4.0"	4.5"	5.0"	5.5"	6.0"	6.0"
32"	1.5"	2.0"	2.5"	3.5"	4.0"	4.5"	5.0"	5.5"	6.0"	6.0"
34"	1.5"	2.0"	2.5"	3.5"	4.0"	4.5"	5.0"	5.5"	6.0"	6.5"
36"	1.5"	2.0"	2.5"	3.5"	4.0"	4.5"	5.0"	5.5"	6.0"	6.5"
38"	1.5"	2.0"	3.0"	3.5"	4.0"	4.5"	5.0"	5.5"	6.0"	6.5"
40"	1.5"	2.0"	3.0"	3.5"	4.0"	4.5"	5.0"	5.5"	6.0"	6.5"

Thicknesses reported in this table are shown for demonstrative purpose only and they are strictly related to boundary conditions reported above. They are calculated using ASTM C680-10 algorithm, without considering any safety coefficient and assuming a perfect design and installation of insulation system. DUNA assumes no responsibility for any use of data shown in this table. We strongly recommend to contact a qualified insulation-design engineer for a proper thickness calculation related to any specific project.

EXAMPLES OF INSULATING SOLUTIONS WITH DUNA-USA PRODUCTS

Overview piping insulation details

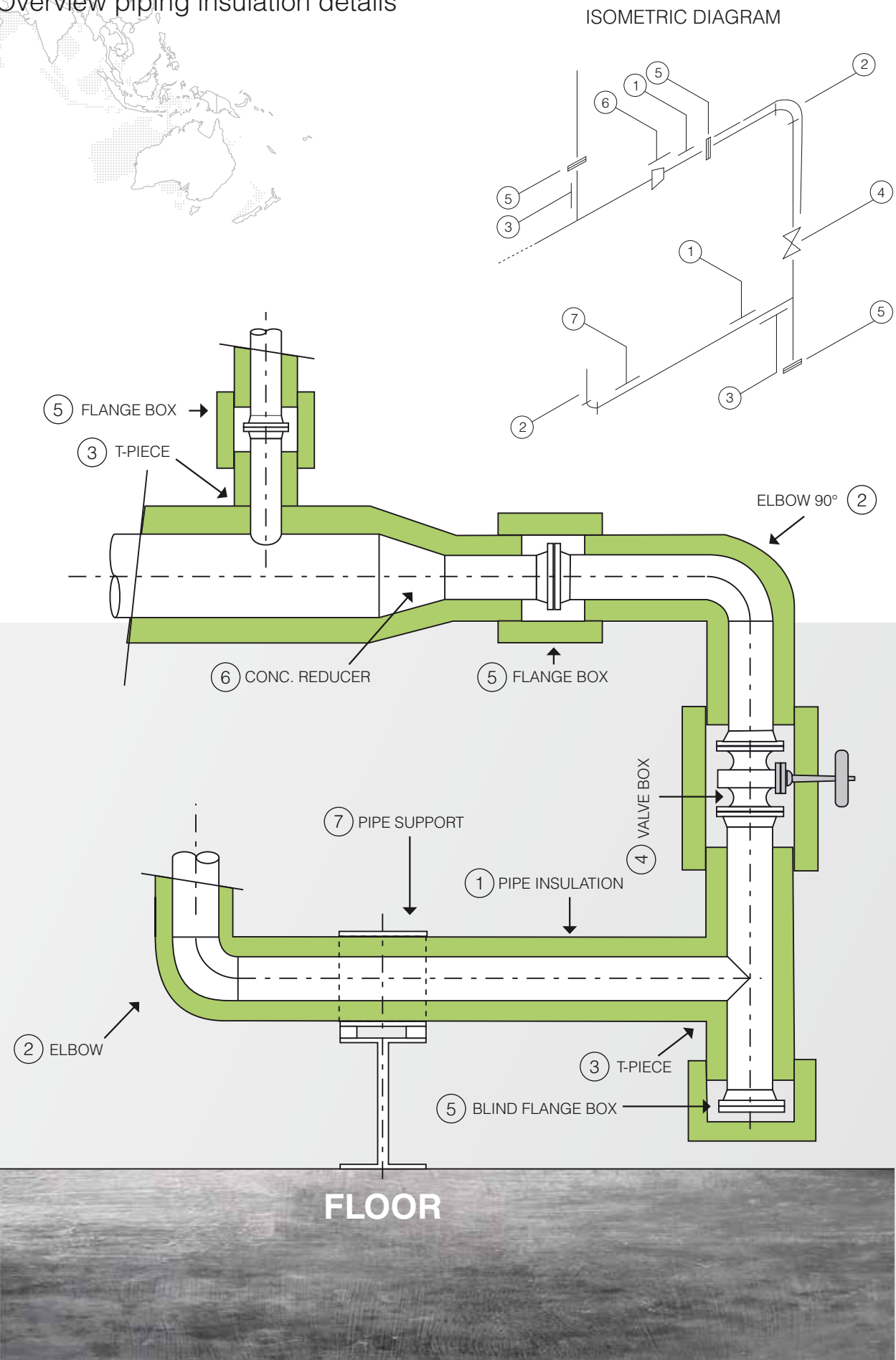

1

STRAIGHT PIPES

All pieces can be single or multilayered, butt joint or (circumferentially AND/OR longitudinally) shiplapped

Single layer, Butt jointed

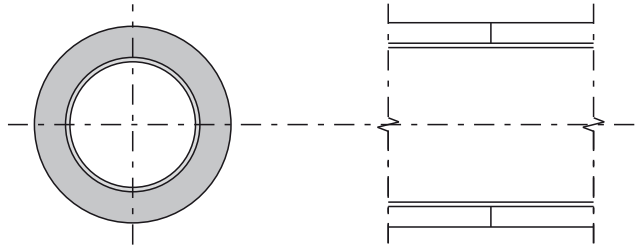

Single layer, longitudinally and circumferentially shiplapped

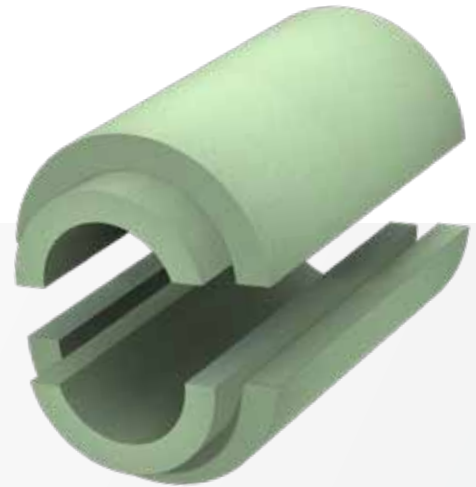
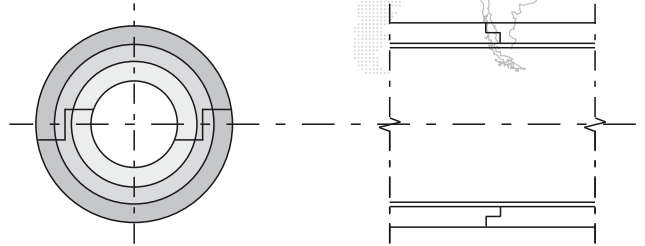

DOUBLE LAYER APPLICATION

All multilayered pipes must be staggered

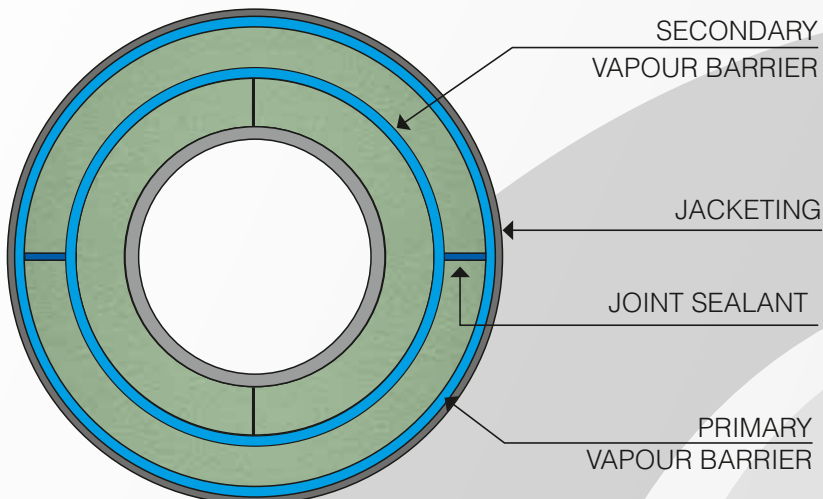

DOUBLE LAYER APPLICATION

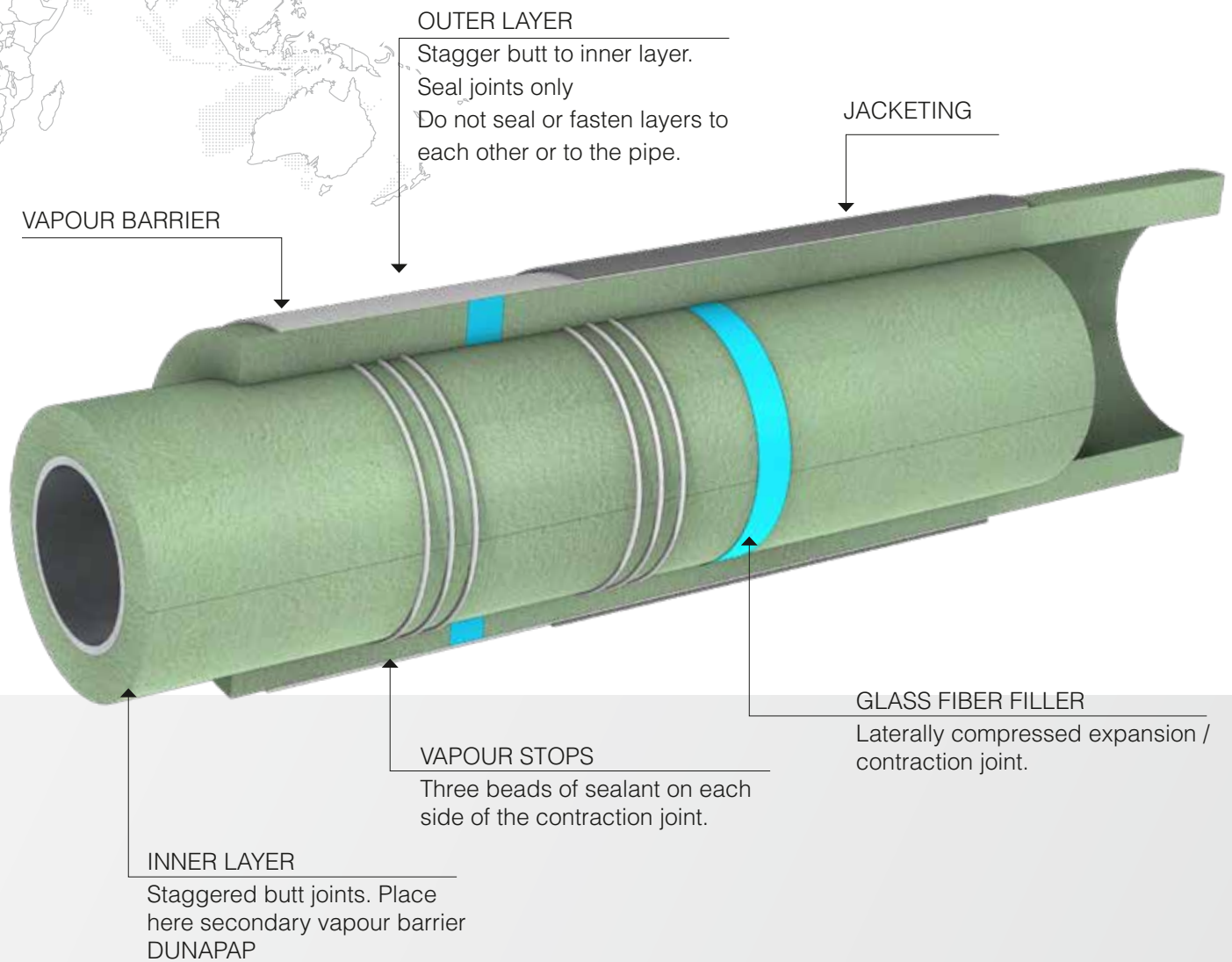

TRIPLE LAYER APPLICATION

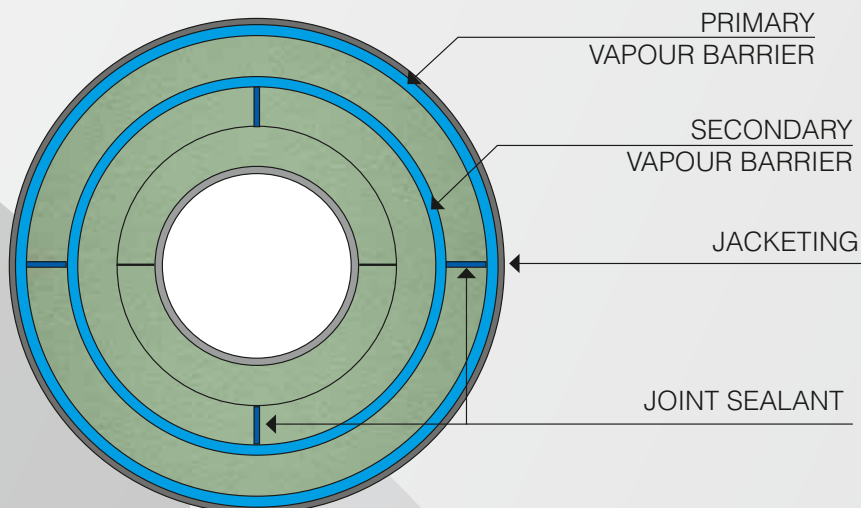

2

ELBOWS

All pieces can be single or multilayered, butt joint or circumferentially AND/OR longitudinally shiplapped,

MITRED ELBOW

MILLED ELBOW

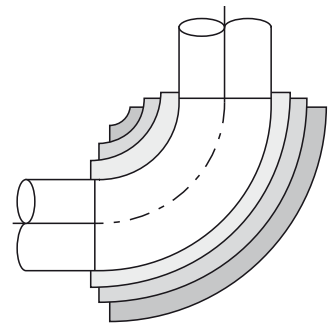
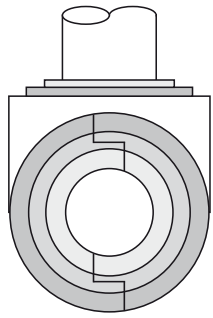
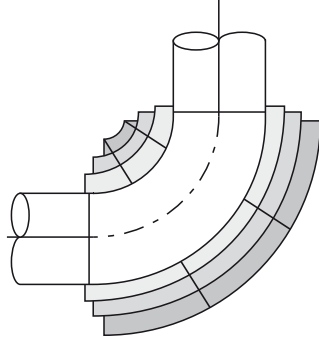
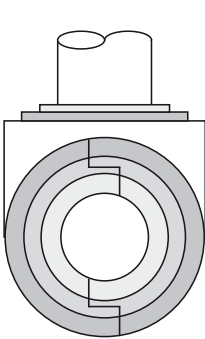

CIRCUMFERENTIALLY ONLY SHIPLAPPED ELBOW



3

TEES

T1 = FABRICATED

T2 = ASSEMBLED

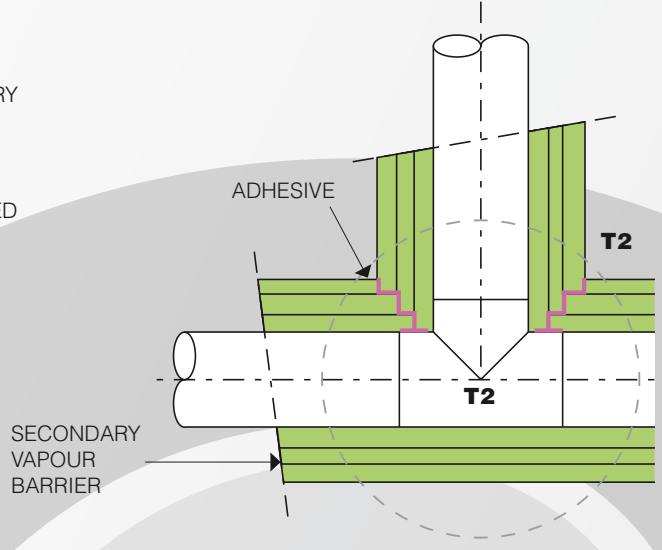
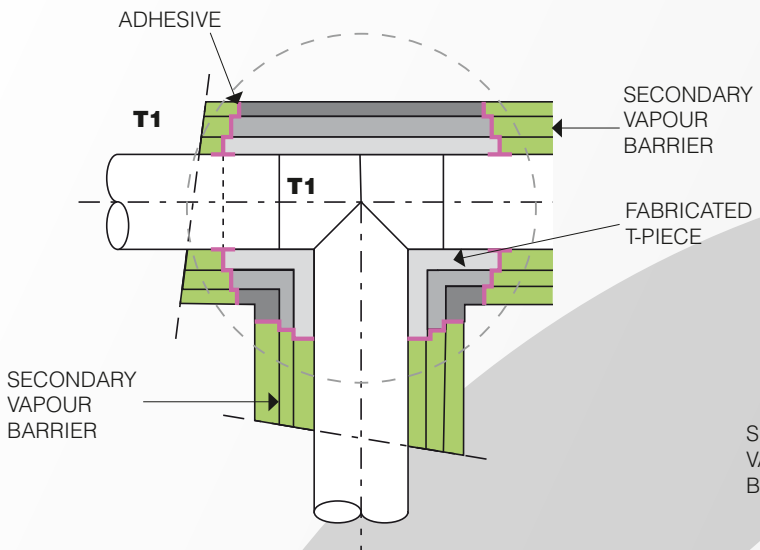

4

VALVES

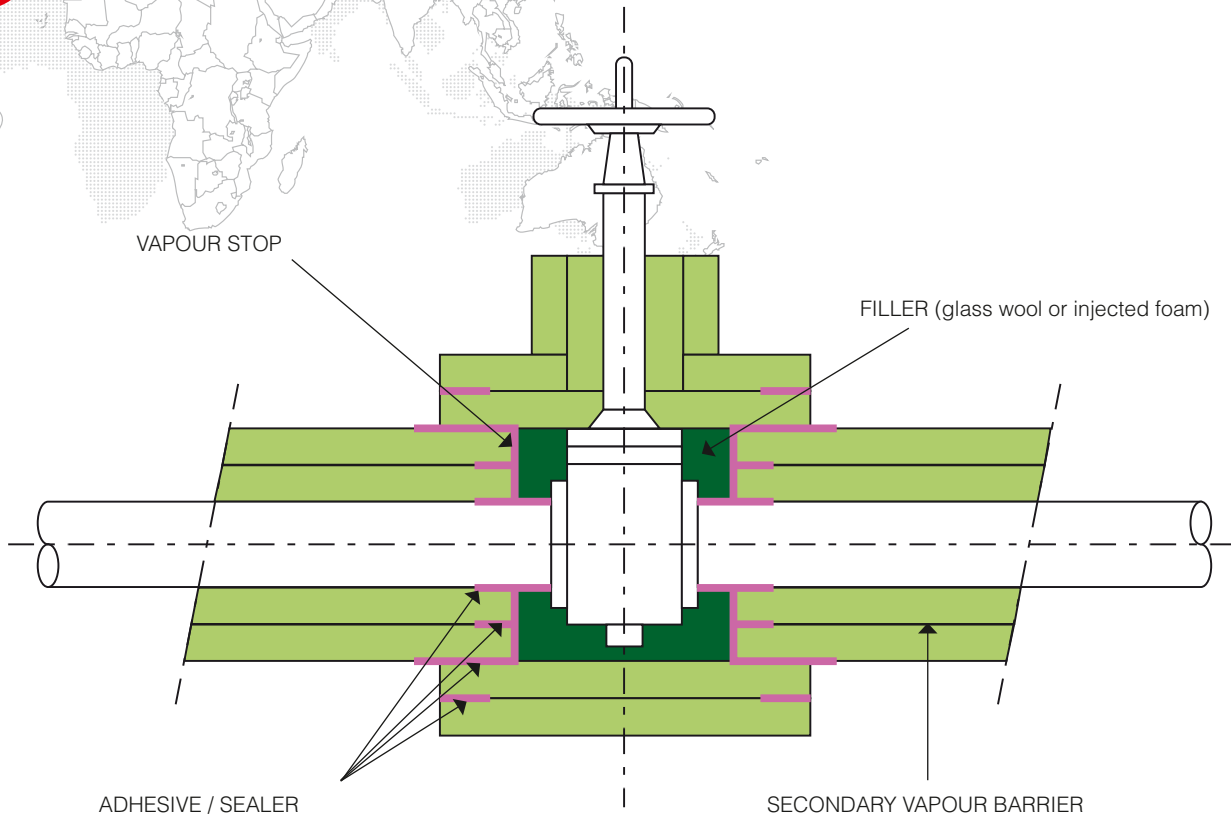

5

FLANGES

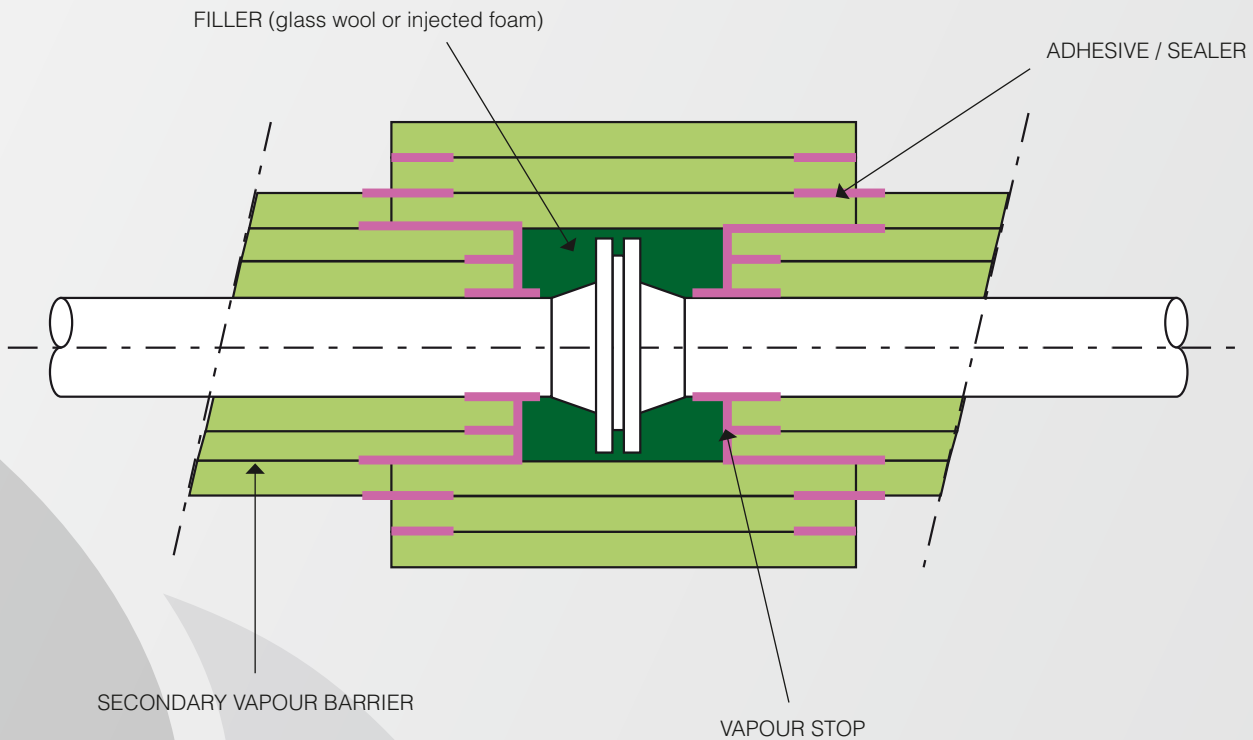

6

REDUCERS

CONCENTRIC

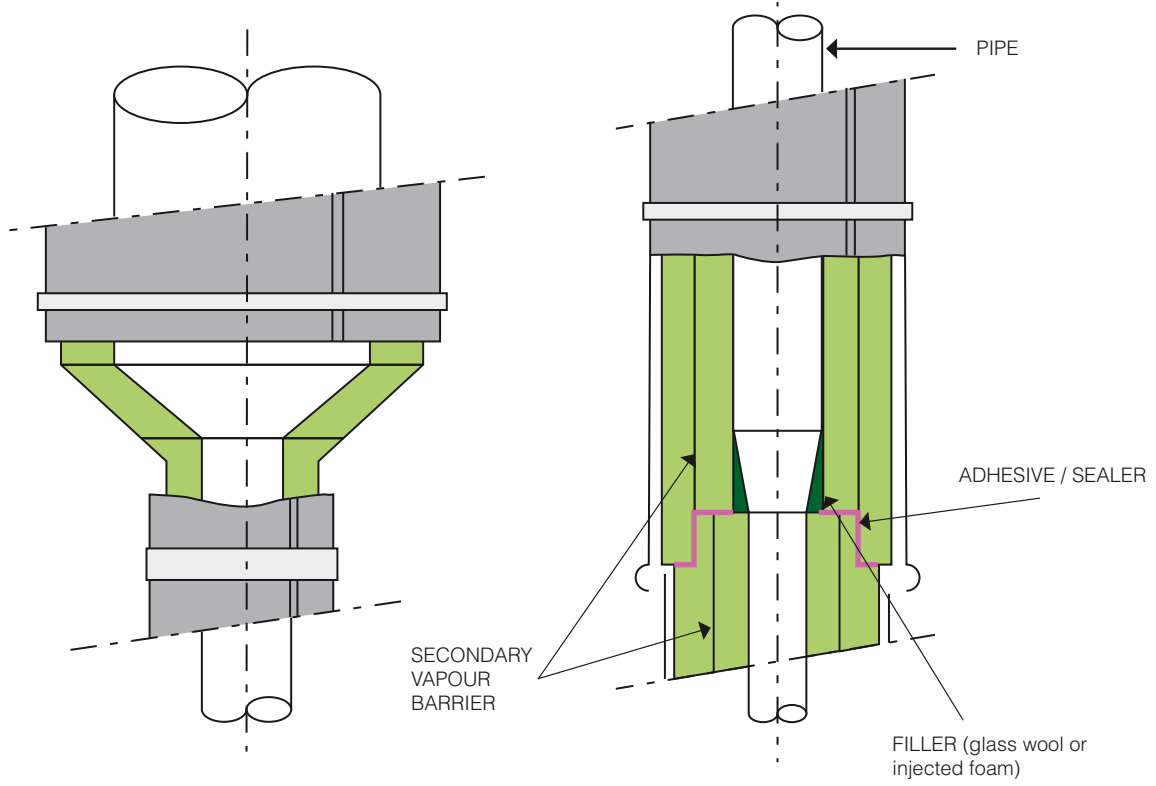

ECCENTRIC

SINGLE LAYER SYSTEM

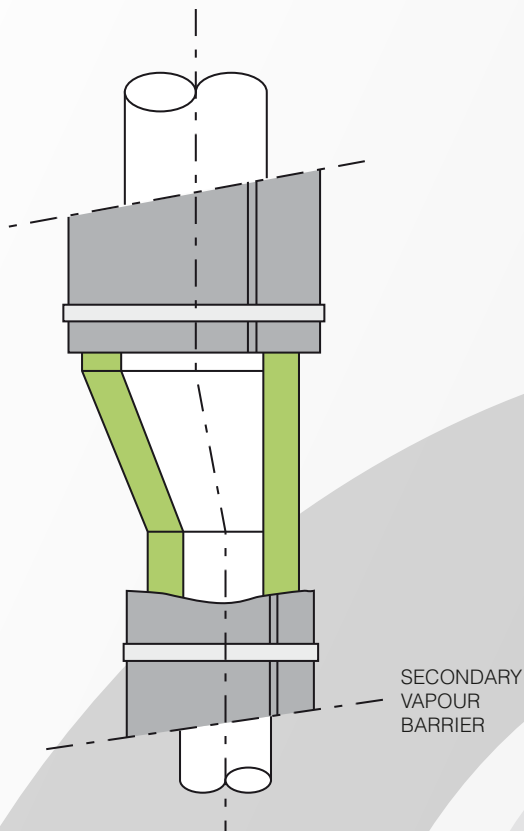

DOUBLE LAYER SYSTEM

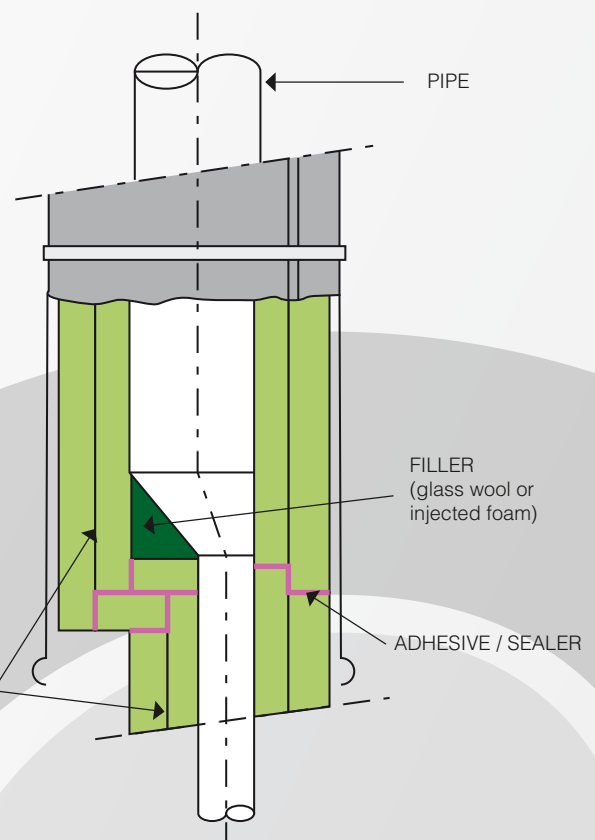

7

INSULATED PIPE SUPPORTS

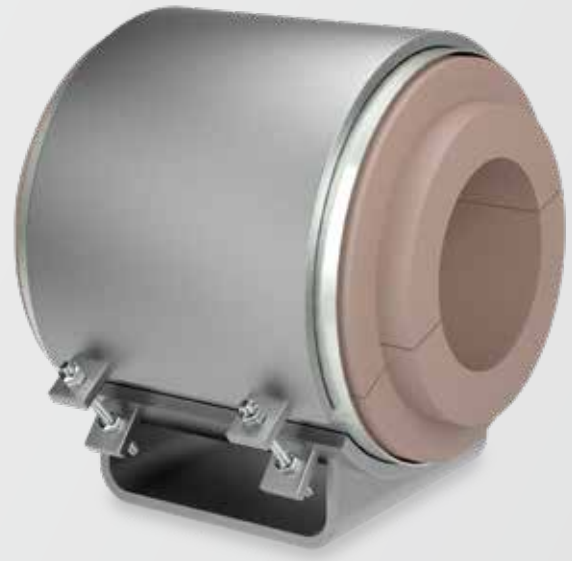
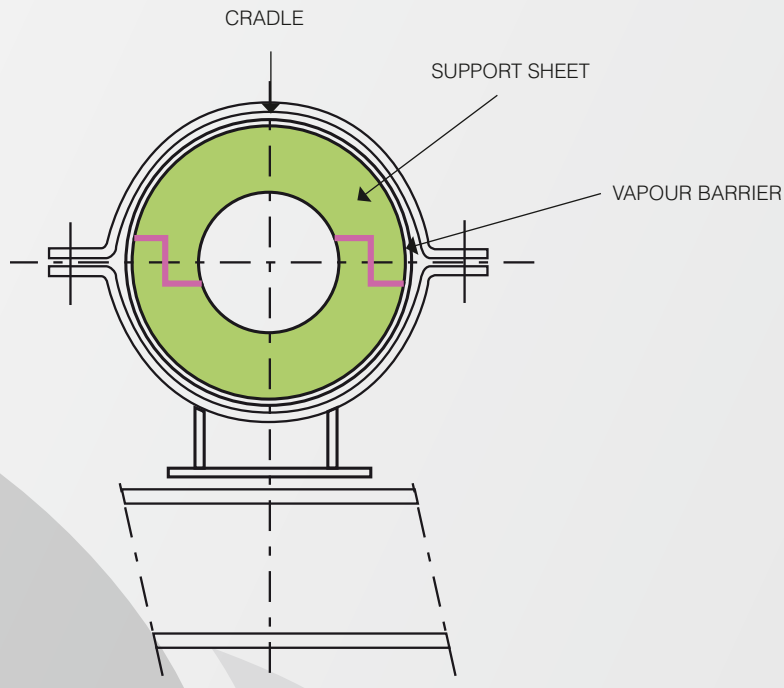
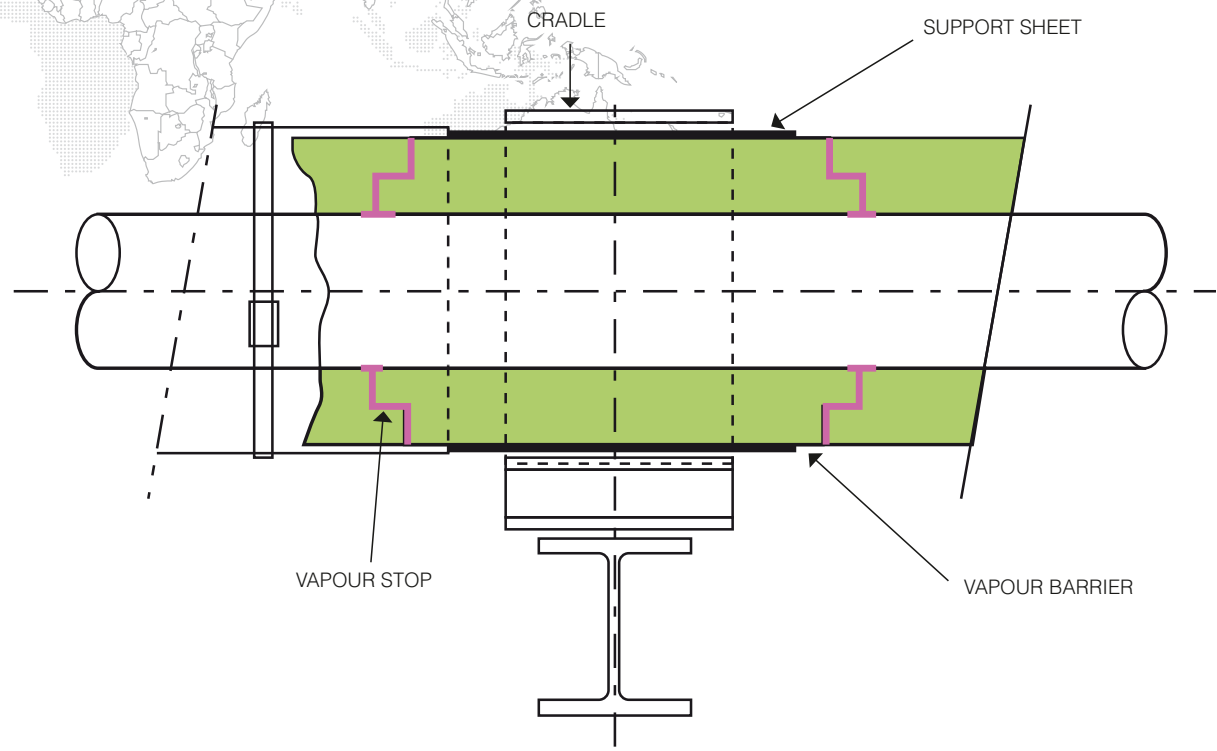

Disclaimer:

This guideline is offered as a handbook for the purpose described herein. No warranty of procedures, either verbalized or involved is intended. All values shown outline typical characteristics and do not constitute in any way a sales specification; they are based on DUNA-Group's current knowledge and experience of the products when properly stored, handled and applied in accordance with our recommendations.

DUNA-Group does not accept any responsibility for incorrect use of its products as it cannot ensure the correct methods of application have been followed; we specifically disclaim any liability for consequential or incidental damages of any kind, including lost profits.

Please always ask for the most recent technical data sheet.

I N N O V A T I O N P R O V I D E R S

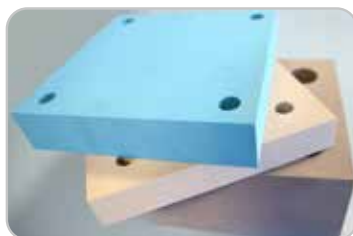
INNOVATION PROVIDERS**DUNA-CORRADINI SpA**

Via Modena Carpi, 388
41019 Soliera,
MODENA, Italy
Tel.: (+39) 059 893911
Fax: (+39) 059 565403

info@dunagroup.com
www.dunagroup.com

**DUNA-USA Inc.**

4210 FM 1405 Baytown, Texas 77523
Tel.: 281-383-3862
TOLL FREE: 866-383-DUNA
Michigan Plant: 5900 West 6th street Ludington,
Michigan 49431

info-dunausa@dunagroup.com
www.dunagroup.com/usa

**DUNA-EMIRATES LLC FZC**

P.O. Box 50024
Fujairah, U.A.E.
Tel.: (+971) 09 228 2409
Fax: (+971) 09 228 2399

info-dunaemirates@dunagroup.com
www.dunagroup.com/emirates